

- PARKING ALLOWED ON BOTH SIDES OF STREET
- UTILIZED IN SINGLE FAMILY RESIDENTIAL AREAS

LOCAL W/ ATTACHED WALK

TO BE USED ONLY WITH WRITTEN PERMISSION FROM THE CITY ENGINEER

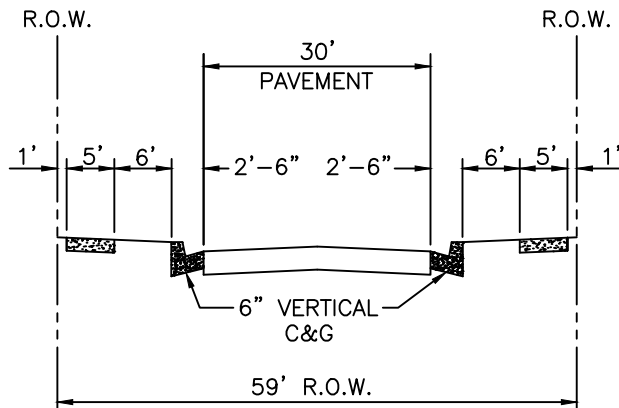

- PARKING ALLOWED ON BOTH SIDES OF STREET
- UTILIZED IN SINGLE FAMILY RESIDENTIAL AREAS

LOCAL W/ DETACHED WALK



**CITY of WESTMINSTER**  
 4800 WEST 92ND AVENUE  
 WESTMINSTER, COLO. 80031

LOCAL  
 TYPICAL SECTIONS

DATE: JANUARY 2019

R1

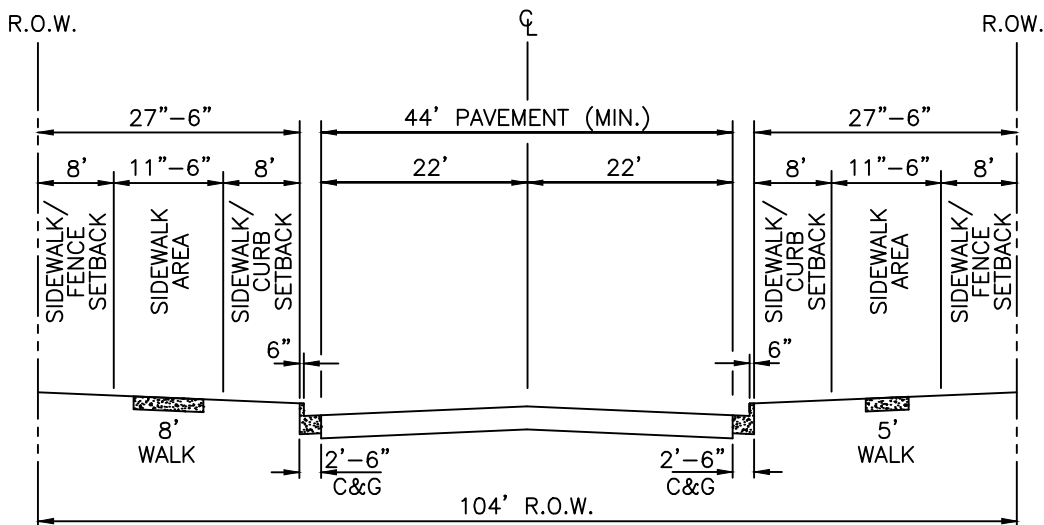

- PROVIDE WIDENING AT INTERSECTIONS FOR LEFT TURN LANES AND DECEL LANES RIGHT-OF-WAY WIDTH TO BE INCREASED TO 105' IN THESE AREAS.
- NO PARKING ALLOWED
- UTILIZED IN AREAS WHERE THERE IS LIMITED ACCESS AND PROJECTED TRAFFIC VOLUMES ARE GREATER THAN 7,000 VEHICLES PER DAY.

### MAJOR COLLECTOR

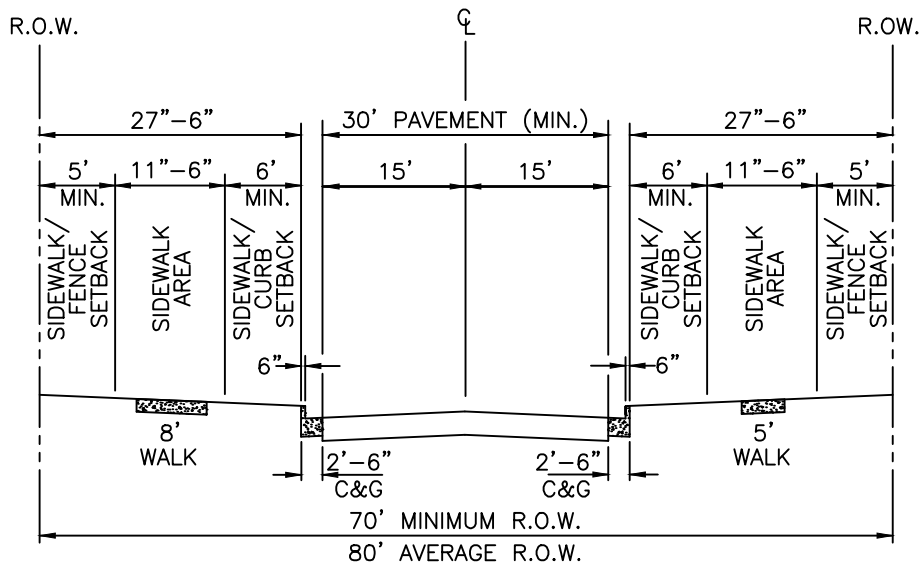

- PARKING ALLOWED
- UTILIZED IN INDUSTRIAL, COMMERCIAL, MULTI-FAMILY, AND SINGLE-FAMILY RESIDENTIAL AREAS WHERE ON-STREET PARKING IS REQUIRED.
- 80' AVERAGE RIGHT-OF-WAY (ROW) IS EXTENDED TO PROVIDE VARYING FENCE ALIGNMENTS ALONG ROW LINE.

### MINOR COLLECTOR



**CITY of WESTMINSTER**  
 4800 WEST 92ND AVENUE  
 WESTMINSTER, COLO. 80031

MAJOR & MINOR COLLECTORS  
 TYPICAL SECTIONS

DATE: JANUARY 2019

R2

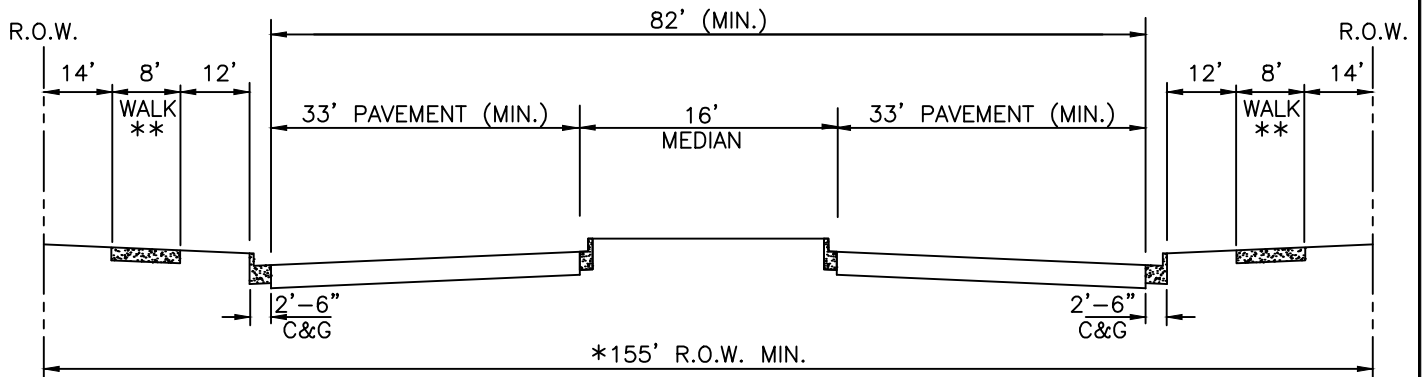

- NO PARKING ALLOWED.
- PROVIDE ACCEL/DECEL LANES AT INTERSECTIONS.
- PROVIDE ACCEL./DECEL. LANES AND DOUBLE TURN LANES AT MAJOR INTERSECTIONS AS NECESSARY.
- \* ● AT MAJOR INTERSECTIONS THE R.O.W. WIDTH SHALL BE 188'.
- \*\* ● 10' OR 12' PATH WHEN DIRECTED BY THE CITY ENGINEER.

### MAJOR ARTERIAL (6-LANE)

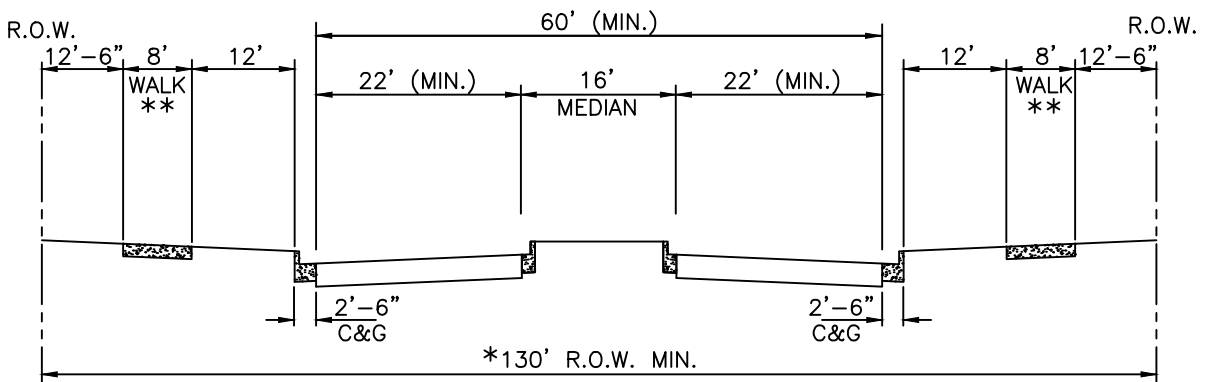

- NO PARKING ALLOWED.
- PROVIDE DECEL LANES AT INTERSECTIONS.
- PROVIDE DECEL. LANES AND DOUBLE LEFT TURN LANES AT MAJOR INTERSECTIONS AS NECESSARY.
- \* ● AT MAJOR INTERSECTIONS THE R.O.W. WIDTH SHALL BE 163'.
- \*\* ● 10' OR 12' PATH WHEN DIRECTED BY THE CITY ENGINEER.

### MAJOR ARTERIAL (4-LANE)

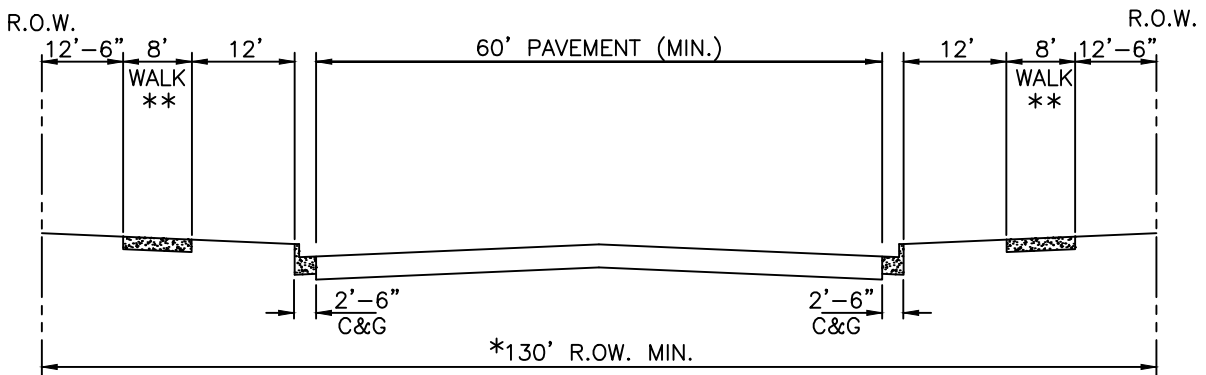

- NO PARKING ALLOWED.
- MEDIAN MAY BE PAINTED OR CURBED.
- \* ● AT MAJOR INTERSECTIONS THE R.O.W. WIDTH SHALL BE 163'.
- \*\* ● 10' OR 12' PATH WHEN DIRECTED BY THE CITY ENGINEER.

### MINOR ARTERIAL



**CITY of WESTMINSTER**  
 4800 WEST 92ND AVENUE  
 WESTMINSTER, COLO. 80031

MAJOR AND MINOR ARTERIAL  
 TYPICAL SECTIONS

DATE: JANUARY 2019

R3